

# OWNERS MANUAL

**Model No.  
45-0301**

**CAUTION:**  
Read Rules for  
Safe Operation  
and Instructions  
Carefully



## **175 LB. POLY PRO SPIKER/SPREADER**

- Safety
- Assembly
- Operation
- Maintenance
- Parts

## RULES FOR SAFE OPERATIONS

Any power equipment can cause injury if operated improperly or if the user does not understand how to operate the equipment. Exercise caution at all times, when using power equipment.

- Read this owner's manual before attempting to assemble or operate the spiker/spreader.
- Read the towing vehicle owner's manual and know how to operate the tractor before using the spiker/spreader attachment.
- Do not allow anyone to ride on or sit on the spiker/spreader.
- Never allow children to operate the tractor or spiker/spreader attachment.
- Do not allow adults to operate the tractor or spiker/spreader without proper instructions.
- Read the chemical label for instructions and cautions for handling and applying chemicals.
- Wear eye and hand protection when handling and using lawn chemicals.
- Always begin with the transmission in first (low) gear and gradually increase speed as conditions permit. Maximum towing speed - 10 M.P.H.
- Do not drive too close to a creek or ditch and be alert for holes and other hazards which could cause you to lose control of the tractor and spiker/spreader.
- Before operating the vehicle on any grade (hill) refer to the safety rules in the vehicle owner's manual concerning safe operation on slopes. **Stay off steep slopes!**
- Follow maintenance and lubrication instructions as outlined in this manual.



Look for this symbol to point out important safety precautions. It means--**Attention!! Become alert!!** Your safety is involved.

### CARTON CONTENTS

- |                     |                       |                      |
|---------------------|-----------------------|----------------------|
| 1. Hopper Assembly  | 4. Hopper Brace       | 7. Flow Control Rod  |
| 2. Chain Cover      | 5. Flow Control Gauge | 8. Tongue Braces (2) |
| 3. Transport Handle | 6. Flow Control Arm   | 9. Tongue            |
|                     |                       | 10. Hitch Bracket    |

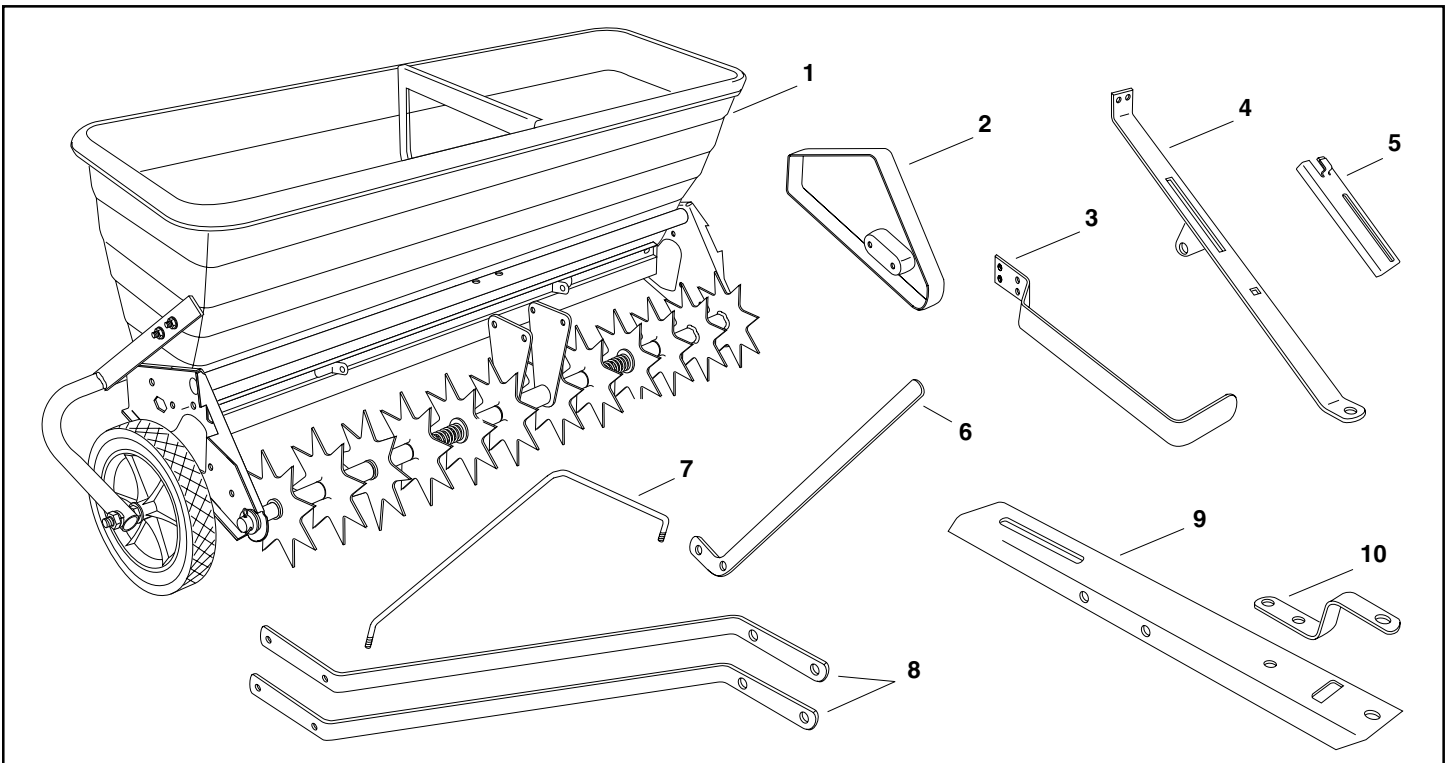

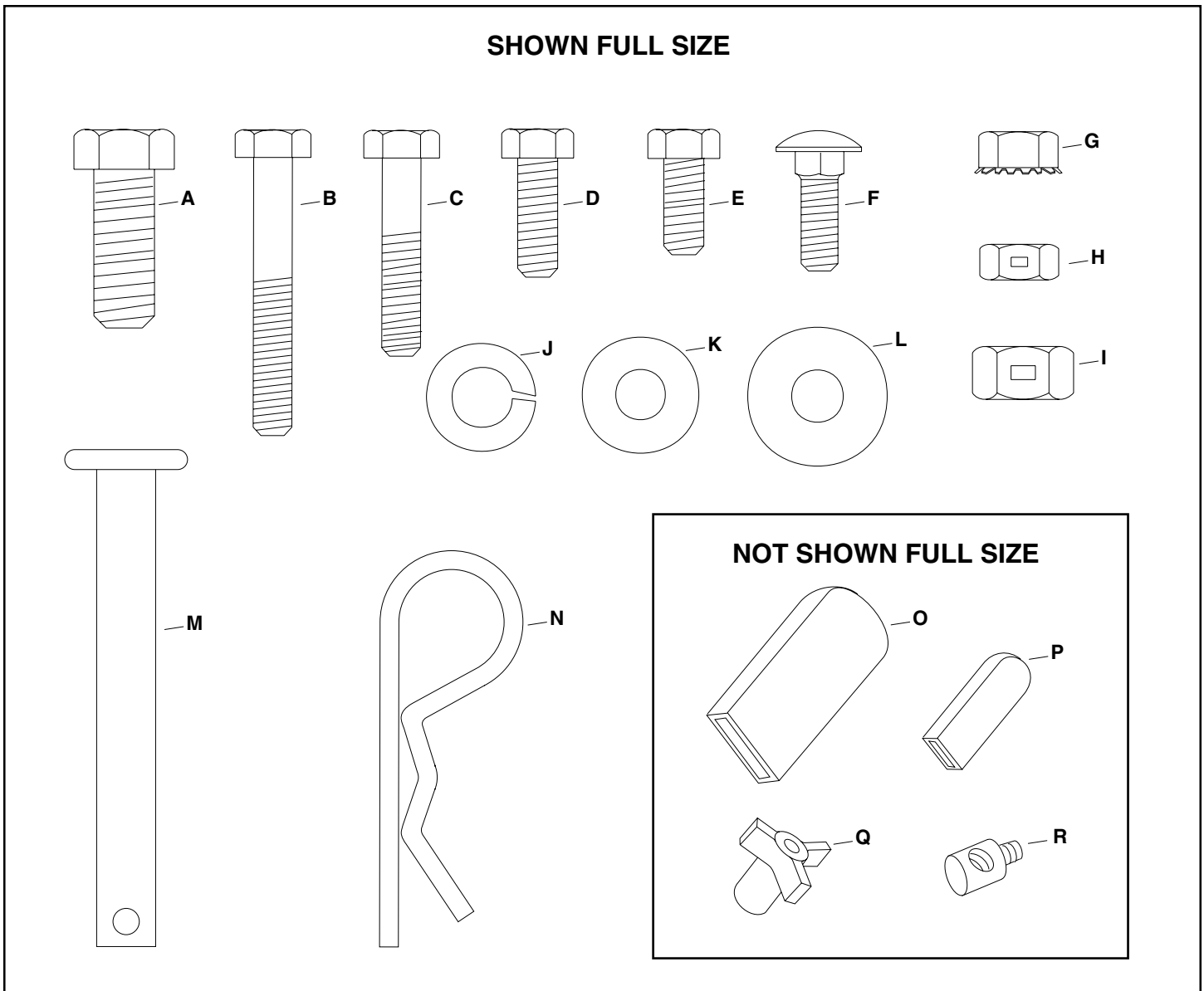

**HARDWARE CHART**

REF.	QTY.	DESCRIPTION	REF.	QTY.	DESCRIPTION
A	1	Hex Bolt, 3/8" x 1"	J	1	Lock Washer, 3/8"
B	2	Hex Bolt, 1/4" x 1-3/4"	K	10	Flat Washer, 1/4"
C	1	Hex Bolt, 1/4" x 1-1/4"	L	3	Nylon Washer
D	2	Hex Bolt, 1/4" x 3/4"	M	1	Hitch Pin
E	16	Hex Bolt, 1/4" x 5/8"	N	1	Hair Cotter Pin, 1/8"
F	1	Carriage Bolt, 1/4" x 3/4"	O	1	Grip, Transport Handle
G	20	Hex Nut, 1/4" (SIMS)	P	1	Grip, Control Arm
H	4	Hex Lock Nut, 1/4"	Q	1	Plastic Knob
I	1	Hex Lock Nut, 3/8"	R	2	Ferrule

## ASSEMBLY

### TOOLS REQUIRED FOR ASSEMBLY

- (2) 7/16" Wrenches
- (2) 1/2" Wrenches
- (2) 9/16" Wrenches
- (2) 3/4" or Adjustable Wrenches (for optional wheel removal in figure 5)



Spike points are sharp. Exercise caution when working with hands near spike disks.

1. Remove the hardware pack and all individual parts from the carton and lay out as shown on pages 2 and 3.
2. Assemble the end of the tongue to the hopper as shown in figure 1 using two 1/4" x 5/8" hex bolts and 1/4" hex nuts. The holes are located just below the frame assembly tube. **Do not tighten yet.**

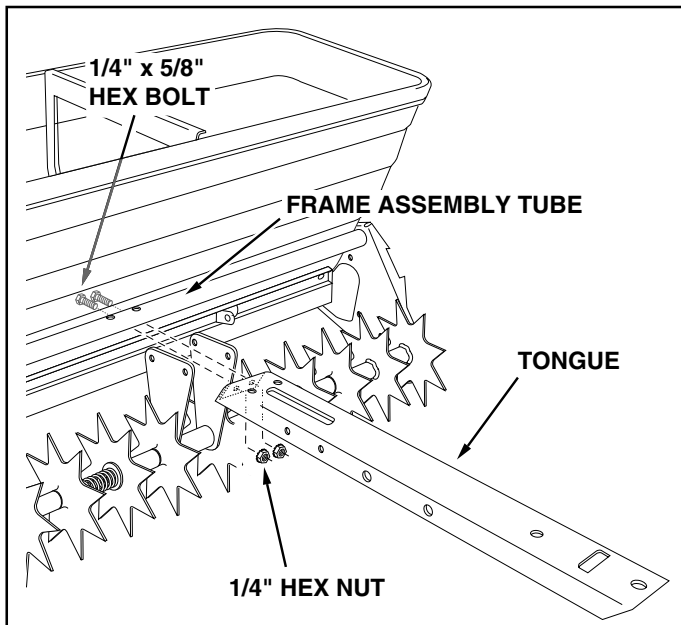

FIGURE 1

3. Attach the tongue to the frame assembly tube using two 1/4" x 1-3/4" hex bolts, four 1/4" flat washers and two 1/4" hex nuts as shown in figure 2. **Do not tighten yet.**
4. Attach the tongue to the two center braces using four 1/4" x 5/8" hex bolts and 1/4" hex nuts as shown in figure 2. **Do not tighten yet.**

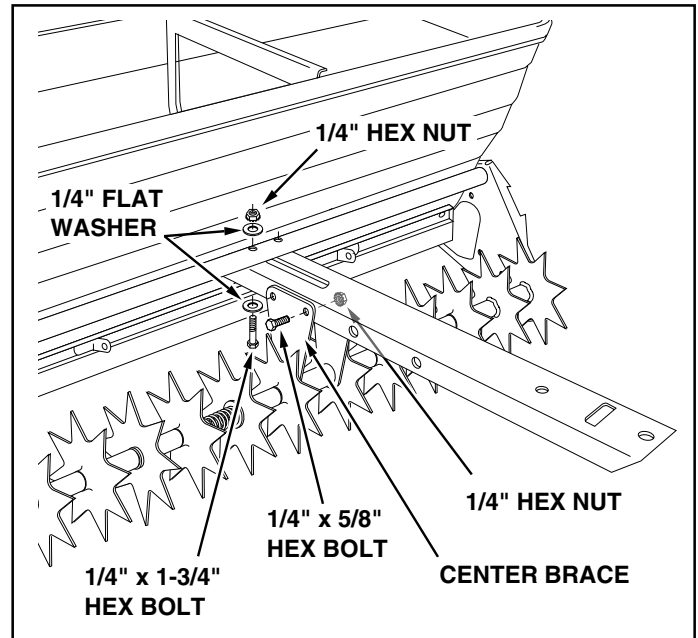

FIGURE 2

5. Assemble the plastic grip onto the end of the flow control arm as shown in figure 3.
6. Insert the flow control arm through the slot in the hopper brace. Place a nylon washer on each side of the arm and attach it to the brace's welded bracket using a 1/4" x 1-1/4" hex bolt, a 1/4" flat washer and two 1/4" hex lock nuts as shown in figure 3. **Tighten** the first hex lock nut until there is noticeable resistance when moving the flow control arm, then **tighten** the second hex lock nut.
7. Place the flow control rod through the hole at the end of the flow control arm. Assemble the two ferrules onto the threaded ends of the rod so that approximately 10 threads (1/2") of the rod extends through the ferrules. See figure 3.

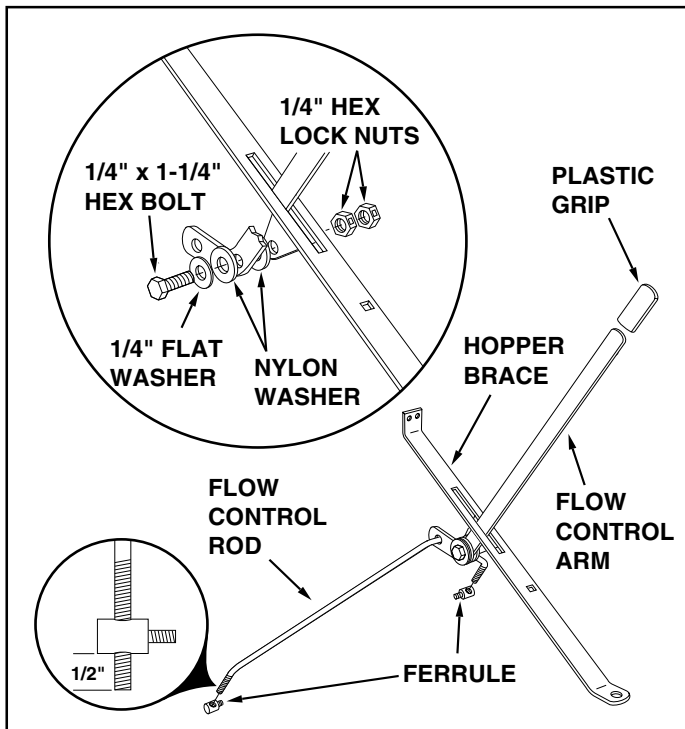

FIGURE 3

8. Attach the hopper brace to the hopper using two 1/4" x 5/8" hex bolts, one 1/4" flat washer and two 1/4" hex nuts. **Do not tighten yet.** See figure 4.
9. Place the end of the hitch bracket with two holes down through the slot in the tongue. Attach the hopper brace to the top of the tongue and the hitch bracket to the bottom using one 3/8" x 1" hex bolt, 3/8" lock washer and 3/8" hex lock nut. **Do not tighten yet.** See figure 4.

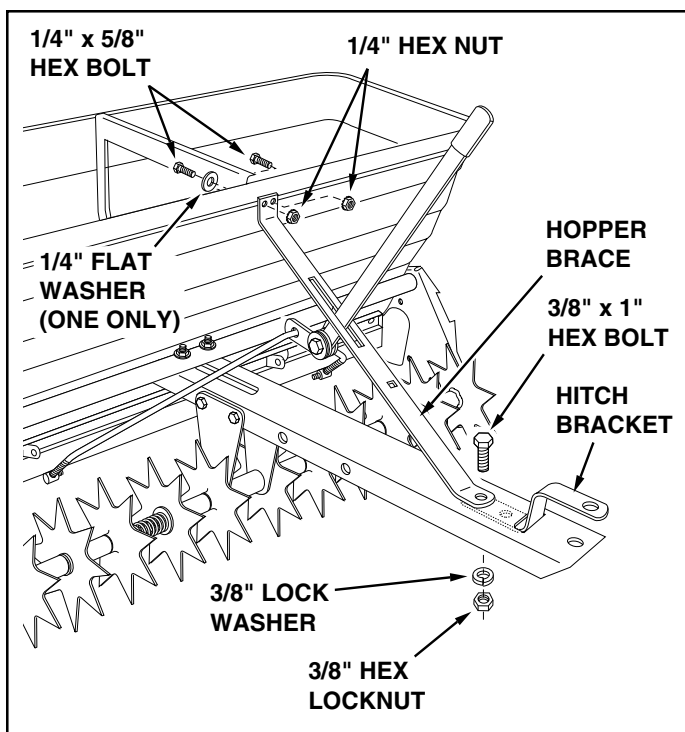

FIGURE 4

**NOTE:** The wheels may be temporarily removed for easier access when assembling the tongue braces in the following instructions.

10. Insert a tongue brace through the slot in the end plate. Fasten the front hole of the tongue brace to the end plate using a 1/4" x 5/8" hex bolt and 1/4" hex nut. For the rear hole use a 1/4" x 3/4" hex bolt, 1/4" flat washer and 1/4" hex nut, with the bolt and washer assembled from inside the poly hopper. See figure 5. **Do not tighten yet.**
11. Fasten the other end of the tongue brace to the side of the tongue using two 1/4" x 5/8" hex bolts and 1/4" hex nuts. **Do not tighten yet.** See figure 5.
12. Repeat steps 10 and 11 for the second tongue brace.
13. **Tighten** all bolts and nuts assembled so far.

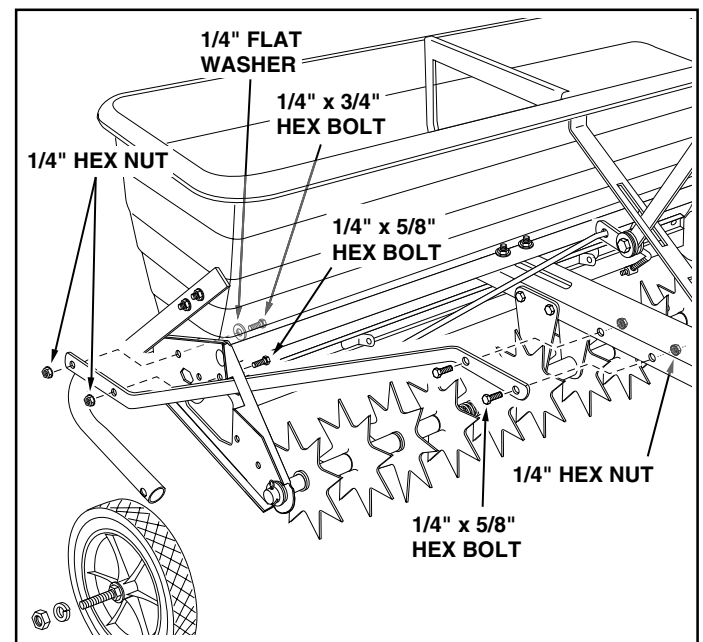

FIGURE 5

14. Assemble the flow control gauge to the hopper brace using the 1/4" x 3/4" carriage bolt, a nylon washer and the plastic knob. See figure 6.

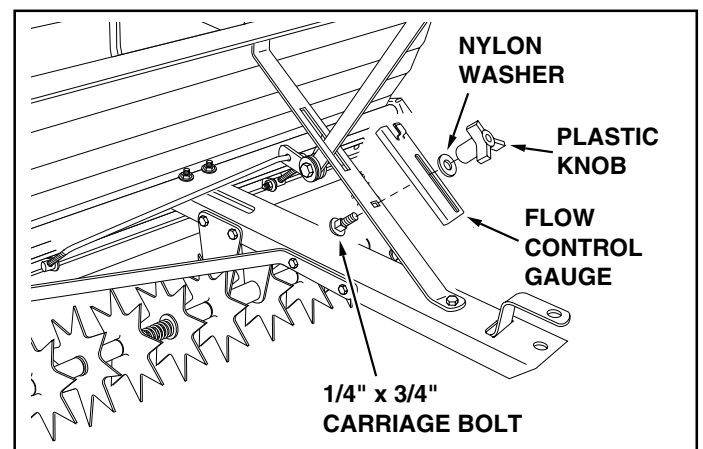

FIGURE 6

15. Check that both ferrules are adjusted so that approximately ten threads (1/2") of the control rod is exposed. Insert both ferrules into the brackets which are riveted to the front of the flow plates. Assemble a 1/4" hex lock nut onto each ferrule, making only **finger tight** at this time. See figure 7.

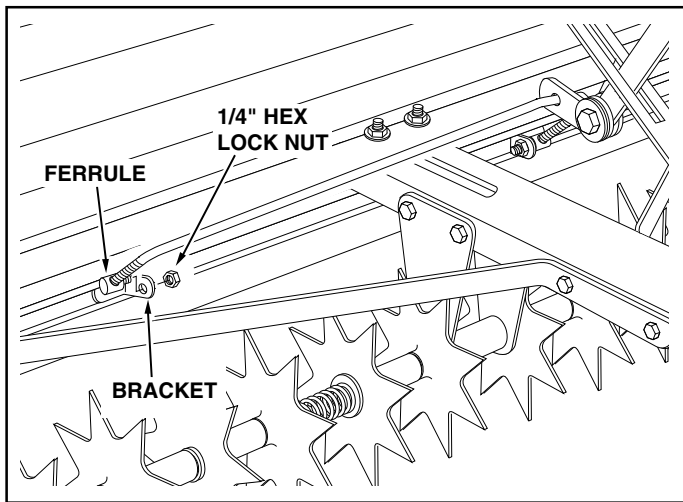

FIGURE 7

16. To check for correct opening of hopper flow plates:
- Set the flow control gauge at the highest setting.
  - Move the flow control arm away from the hopper until it rests against the gauge. The slots in the bottom of the hopper should now be completely open. The edge of the flow plates should be just clear of the ends all the slots.
  - If the flow plates are not straight with the slots, screw one ferrule up or down on one side of the control rod.
  - If the flow plates open to far or not far enough, screw both ferrules equally up or down on the control rod.
  - Move the flow control arm toward the hopper to the off position. Verify that the slots in the bottom of the hopper are completely covered by the flow plates.
  - Tighten** the lock nuts and then loosen 1/4 turn.
17. To check for proper tension on the hopper flow plates:
- Set the flow control gauge at a mid range setting.
  - Move the flow control arm against the gauge.
  - Press firmly against the front of the flow plates at the bottom of the hopper. The flow control arm should not move.
  - If the arm moves, tighten the hex lock nuts on the flow control arm until movement is prevented.

18. Remove the two 5/16" lock washers and 5/16" hex nuts from the carriage bolts which are pre-assembled to the lift assembly arm. Attach the transport handle to the arm using the lock washers and hex nuts which you removed. See figure 8.

19. Assemble the handle grip to the transport handle. See figure 8.

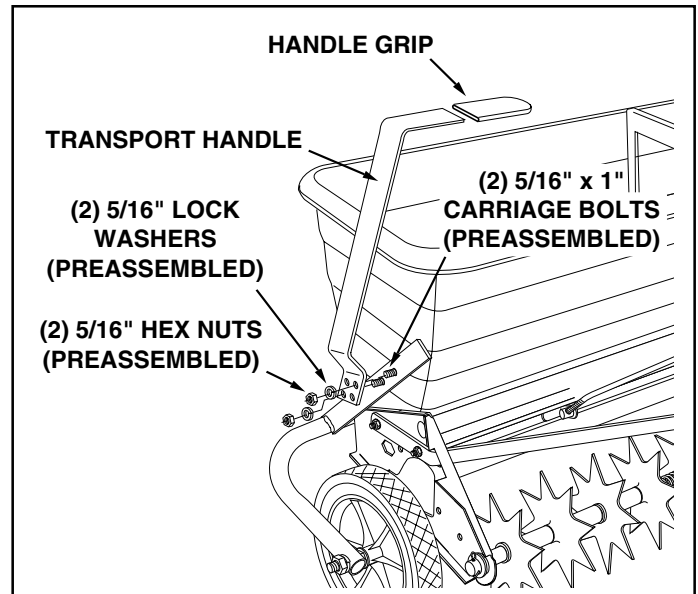

FIGURE 8

20. Assemble the chain cover to the frame assembly using two 1/4" x 5/8" hex bolts, 1/4" flat washers and 1/4" hex nuts as shown figure 9.

21. Install the hitch pin and the 1/8" hair cotter pin in the spreader hitch bracket and tongue. See figure 9.

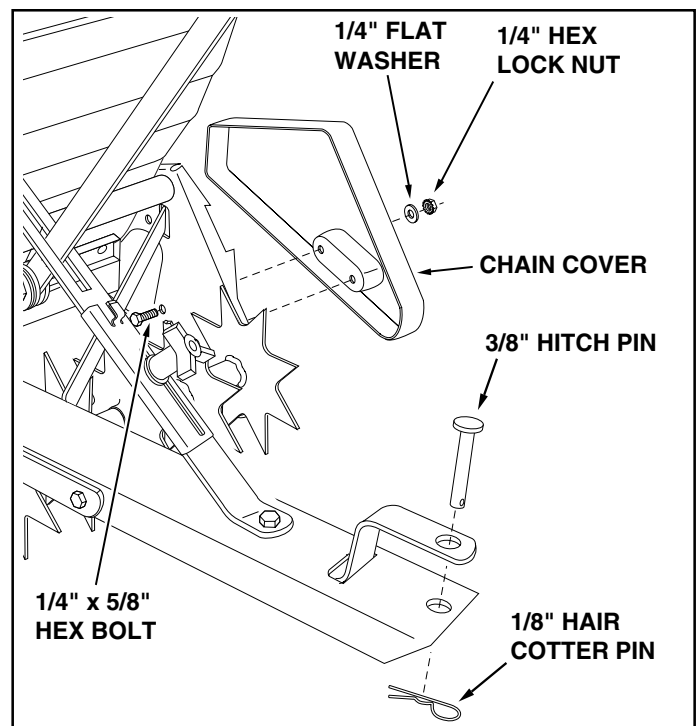

FIGURE 9

## OPERATION

### HOW TO USE YOUR SPIKER/SPREADER

1. Refer to the instruction label on the material package and to the instruction decal on your spreader to help determine the proper spreader setting and application rate. Also see the Setting Chart on this page for a general range of settings for commonly used materials.
2. Loosen the knob and adjust the flow control gauge to the recommended setting. Retighten the knob. See figure 10.
3. Determine the approximate square footage of the area to be covered and estimate the amount of fertilizer or seed required.
4. Move the spiker/spreader to the area where application is to begin.
5. Making sure the flow control arm is in the "OFF" position, fill the hopper, breaking up any lumps.
6. Lower the aerator spikes to the operating position.
7. Start the spreader in motion and then pull the flow control arm forward to the "ON" position as you travel across your lawn. The recommended towing speed is 3 m.p.h.
8. Do not make sharp turns with spikes in the ground.
9. Raise aerator spikes to transport position when crossing over concrete or other hard surfaces.
10. Do not aerate if the ground is extremely hard or dry. If ground is too dry, sprinkle or water for one to two hours prior to use.
11. Do not aerate if the ground is too wet (muddy).

**IMPORTANT:** Always move flow control arm to "OFF" position to prevent excessive release of fertilizer when stopping, turning or filling the spreader.

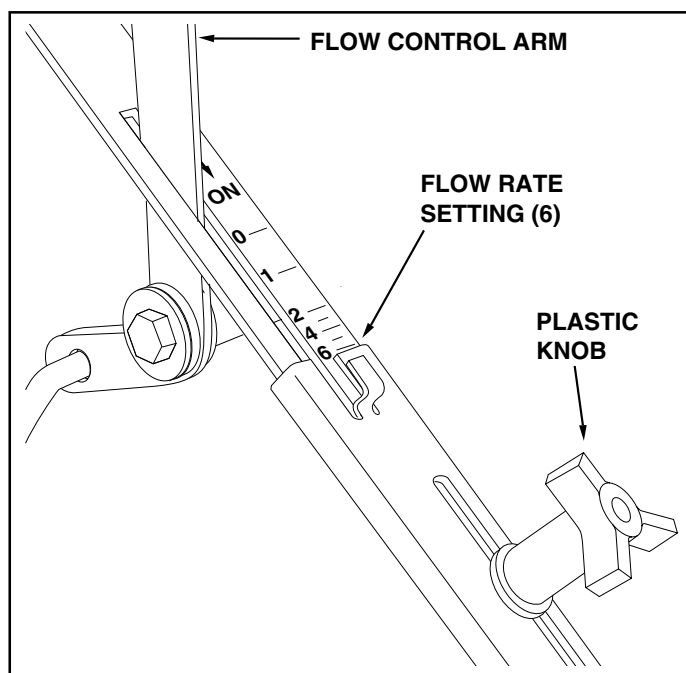

FIGURE 10

## SETTING CHART

MATERIAL	TYPE	Flow Rate Setting At 3 M.P.H.
Fertilizer	Granular / Pelleted	0-1 / 0-2
Grass Seed	Fine / Coarse	5-6 / 7-8

3 M.P.H. is equivalent to traveling 100 feet in 23 seconds.

### APPLICATION TIPS

1. To help prevent compacting and clogging when using **granular** material, avoid unnecessary towing while hopper is filled.
2. Reduce the flow setting for speeds slower than 3 M.P.H. and increase the setting for higher speeds.
3. To avoid misses or striping, overlap the previous pass slightly. Spread width is approximately 40".
4. For easiest application, first apply material across both ends of the area. Two or three passes on each end are sufficient. Then apply material back and forth as shown. Use the end areas for turning around, shutting off the spreader as you enter the end areas and turning the spreader on again as your leave the end areas for your next pass. See figure 11.
5. If lawn is odd shaped, spread a border around the edges and then spread between the border.
6. Be careful when spreading around ornamental plants because weed control chemicals can damage these plants.

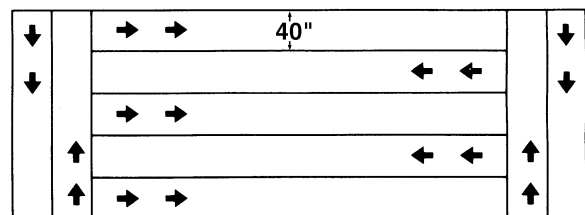

FIGURE 11



Spike points are sharp. Exercise caution when working with hands near spike disks.

## MAINTENANCE

1. Check nuts and bolts for tightness before each use.
2. Always empty hopper after each use, storing leftover material in it's original bag.
3. Wash and dry thoroughly after each use.
4. Apply a light coat of oil on exposed metal parts to help prevent rust.
5. At least once a year, apply a few drops of oil to wheels and to plastic bearings in spike disks, at ends of aerator shaft and at ends of hopper shaft.
6. Clean and oil drive chain once a year.

PARTS FOR 175 LB. POLY "PRO" SPIKER/SPREADER MODEL 45-0301

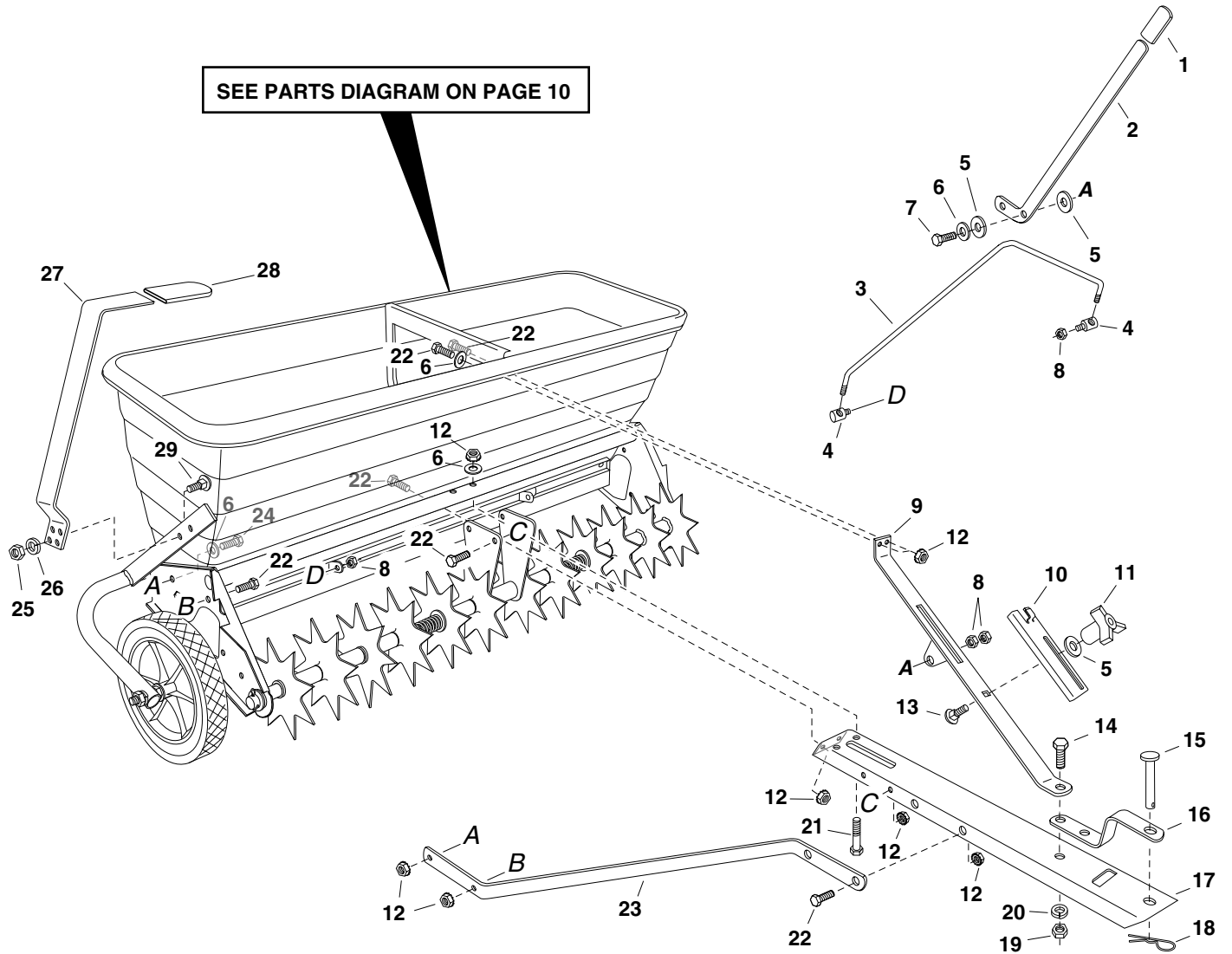



**PARTS FOR 175 LB. POLY "PRO" SPIKER/SPREADER MODEL 45-0301**

REF. NO.	PART NO.	QTY.	DESCRIPTION	REF. NO.	PART NO.	QTY.	DESCRIPTION
1	43848	1	Grip, Plastic	15	47623	1	Pin, Hitch 3/8" Flat Hd.
2	24660	1	Arm, Flow Control	16	23014	1	Hitch Bracket
3	47712	1	Rod, Flow Control	17	24531	1	Tongue
4	47711	2	Ferrule	18	43343	1	Pin, Hair Cotter #4 (1/8")
5	1543-69	3	Washer, Nylon	19	43082	1	Nut, Hex Lock 3/8-16 Thd.
6	43088	10	Washer, 1/4"	20	43003	1	Lock Washer, 3/8"
7	1509-90	1	Bolt, Hex 1/4-20 x 1-1/4" Lg.	21	1509-69	2	Bolt, Hex 1/4-20 x 1-3/4" Lg.
8	43013	4	Nut, Hex Lock 1/4-20 Thd.	22	43866	16	Bolt, Hex 1/4-20 x 5/8"
9	63850	1	Brace Assembly, Hopper	23	24532	2	Brace, Tongue
10	24542	1	Gauge, Flow Control	24	43012	2	Bolt, Hex 1/4-20 x 3/4"
11	43849	1	Knob, Plastic 1/4-20 Thd.	25	43083	2	Nut, Hex 5/16-18
12	46978	20	Nut, Hex (SIMS) 1/4-20 Thd.	26	43086	2	Lock Washer, 5/16"
13	44950	1	Bolt, Carriage 1/4-20 x 3/4" Lg.	27	24647	1	Bar, Transport Handle
14	43001	1	Bolt, Hex 3/8-16 x 1" Lg.	28	47707	1	Grip, Handle
				29	44326	2	Bolt, Carriage 5/16-18 x 1"

PARTS FOR 175 LB. POLY "PRO" SPIKER/SPREADER MODEL 45-0301

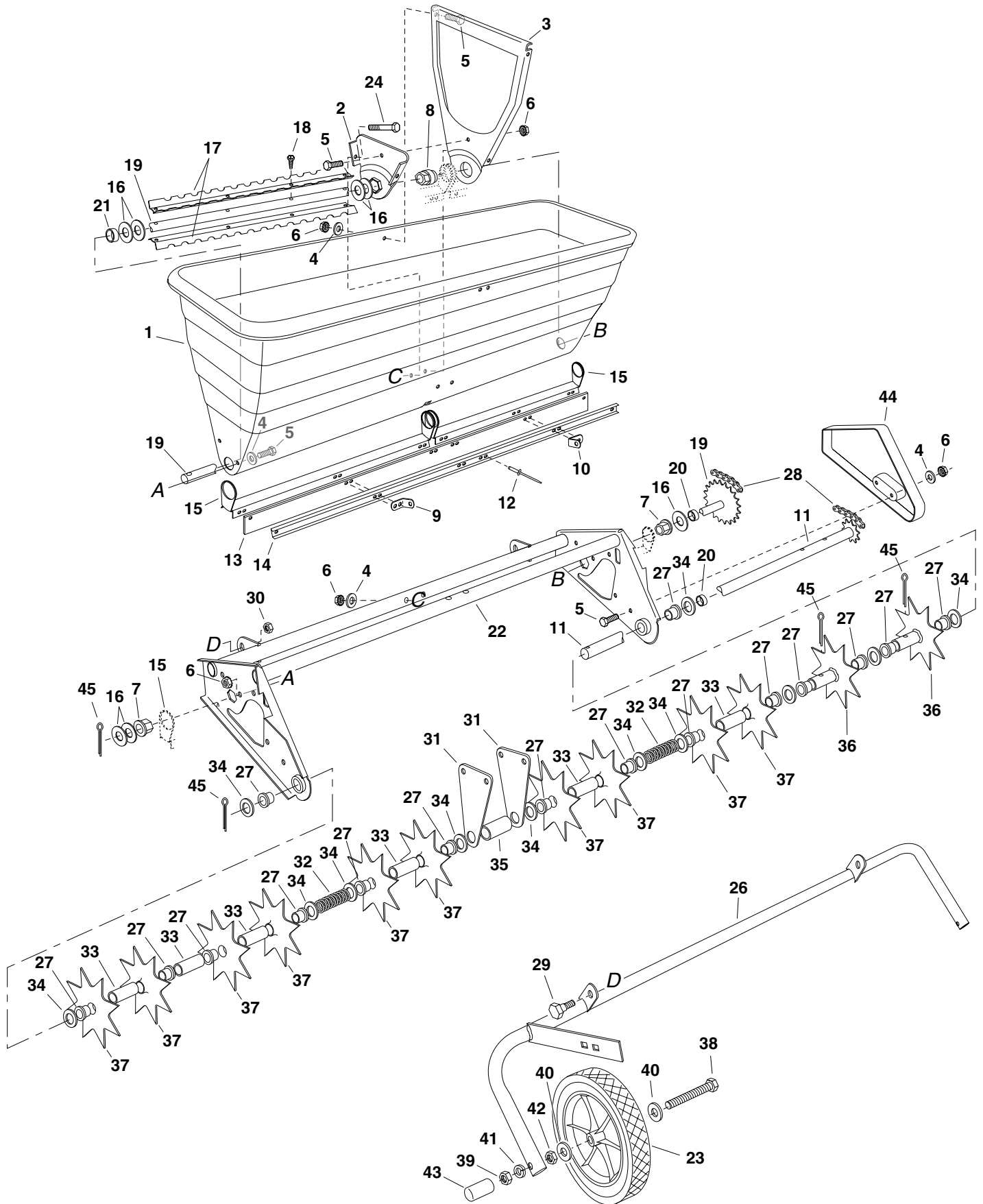

**PARTS FOR 175 LB. POLY "PRO" SPIKER/SPREADER MODEL 45-0301**

REF. NO.	PART NO.	QTY.	DESCRIPTION	REF. NO.	PART NO.	QTY.	DESCRIPTION
1	47451	1	Hopper	24	1509-69	2	Bolt, Hex 1/4-20 x 1-3/4" Lg.
2	24536	1	Hopper Center Plate (Small)	26	63958	1	Lift Tube Assembly
3	24535	1	Hopper Center Plate (Large)	27	741-0249	18	Bearing, Flanged 0.63" I.D.
4	43088	5	Washer, 1/4"	28	47684	1	Chain
5	43866	4	Bolt, Hex 1/4-20 x 5/8"	29	48106	2	Bolt, Shoulder 3/8-16 x 5/8"
6	46978	6	Nut, Hex (SIMS) 1/4-20 Thd.	30	43082	2	Nut, Hex Lock 3/8-16
7	47615	2	Bearing, Flange	31	24648	2	Brace, Center
8	47484	1	Bearing, Hex Flange	32	47777	2	Spring, Compression
9	24538	1	Bracket, Feed Plate (RH)	33	47683	6	Spacer, .75" x 1.0" x 2.98"
10	24539	1	Bracket, Feed Plate (LH)	34	R19212016	12	Washer, 21/32 x 1-1/4 x 16 ga.
11	63949	1	Axle w/Sprocket, 5/8"	35	47782	1	Spacer, 1.0" I.D. x 3.25"
12	728-3001	10	Pop Rivet	36	63956	2	Drive Disk Assembly
13	47459	1	Skirt, 48"	37	24332	10	Spike Disk (7")
14	47508	1	Retainer, Skirt	38	45100	2	Bolt, Hex 1/2-13 x 4"
15	24537	2	Flow Plate	39	712-0206	2	Nut, Hex 1/2-13
16	43009	12	Washer	40	R19171616	4	Washer, 17/32" x 1" x 16 ga.
17	47259	4	Agitator Blade	41	43353	2	Lock Washer, 1/2"
18	47476	16	Screw, #8-32 x 3/8" Lg.	42	43019	2	Nut, Hex Jam 1/2-13
19	63948	1	Axle w/sprocket. 3/4"	43	44688	2	Cap, Plastic
20	46838	2	Spacer, .76" x 1.0" x 0.50"	44	47679	1	Chain Cover
21	47458	2	Spacer, 1.25" OD x .330" Lg.	45	43093	4	Cotter Pin, 1/8" x 1-1/2"
22	63955	1	Hopper Frame Assembly		47685	1	Owners Manual
23	46254	2	Wheel				

For Agri Fab Discount Parts Call 606-678-9623 or 606-561-4983

**REPAIR PARTS**

303 West Raymond

Sullivan, IL. 61951

217-728-8388 / [www.agri-fab.com](http://www.agri-fab.com)

[www.mymowerparts.com](http://www.mymowerparts.com)